



SHELTON
AIR COOLED
CHILLERS
SAE-AC5 with
Hot Gas Bypass

Designed Cooling Capacity of 13.6 kW

Outlet temperature preset of 7°C

Fixed Speed DOL Compressor

Hot Gas Bypass Technology

Stainless steel chilled water pump

Stainless steel plate type evaporator

75L expansion water tank

Single speed low noise condenser fan

Proudly assembled in Singapore



COMPRESSOR

- 1 No of Compressor (DOL – Fixed speed)
 - Japanese High Efficiency Scroll Compressor
 - Power input : 4.3 kW / 8.1 A
- Single refrigerant circuit

WATER CIRCUIT



- 1 No of Circulation Water Pump
 - Stainless Steel 304 Horizontal Multistage Centrifugal
 - Duty Flow rate : 2.3 m³/hr (10.3 US GPM)
 - Duty Pressure : 58 PSI (4 Bar)
 - Power input : 0.75 kW / 1.83 A
- 75L Stainless Steel Insulated Buffer Water Tank

AIR COOLED CONDENSER



- Single Speed Axial Fan
 - 525mm Diameter, 900 RPM low noise fan
 - Air flow of 6200 m³/hr
 - Power input : 0.25 kW / 0.8 A
- Optimized Copper Tube Aluminum Fin Ambient Air Cooled Condenser



HEAT EXCHANGER

- Stainless Steel 316 Copper Brazed Plate Type
- Efficient heat transfer with small footprint



POWER REQUIREMENTS

Incoming Power : 3 PH 400V 50Hz
Total Input Power : 5.5 kW
Total Current : 11 A
Recommended Breaker : 20A TYPE C/D



CONFIGURATIONS

Adjustable Temperature Range : 7°C - 35°C
Capacity Control : 0% / 100% via Hot Gas Bypass
Inlet Connection : DN25 (1 Inch)
Outlet Connection : DN25 (1 Inch)
Length : 1150 mm
Width : 740 mm
Height : 1375 mm
Weight : 220 kg







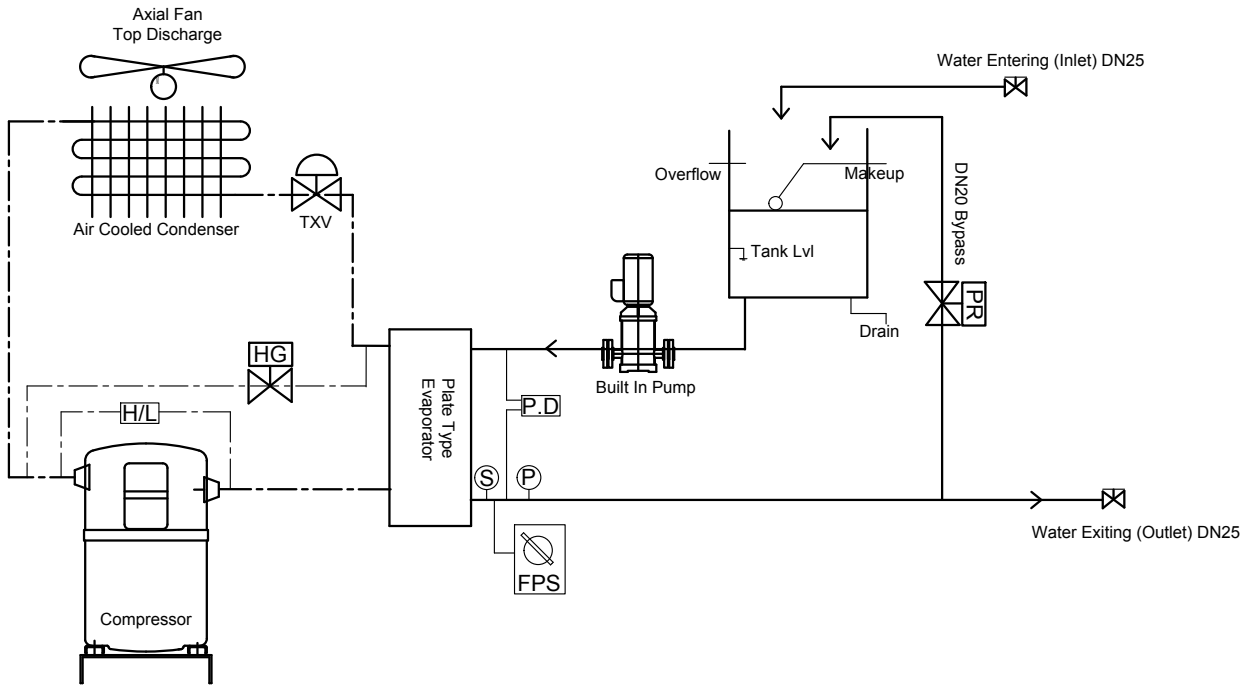

SAFETY PROTECTION DEVICES



High Refrigerant Discharge Pressure Switch
Low Refrigerant Discharge Pressure Switch
Condenser Overload
Water Pumps Overload
Compressor Overload
Anti Freeze Backup for Primary Sensor
Pressure Differential Flow Switch
Automatic over pressure relief valve

CHILLER SCHEMATIC DRAWING

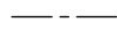

-  Pressure Differential Flow Switch
-  Refrigerant High / Low Pressure Switch
-  Hot Gas Bypass Solenoid Valve
-  Thermal Expansion Valve

-  Freeze Point Sensor
-  Water Temperature Sensor (Digital)
-  Water Pressure Gauge (Analog)
-  Water Isolation Valve
-  Water Over Pressure Relief Valve

-  Refrigerant Circuit
-  Water Circuit

CHILLER DIMENSIONAL DRAWING

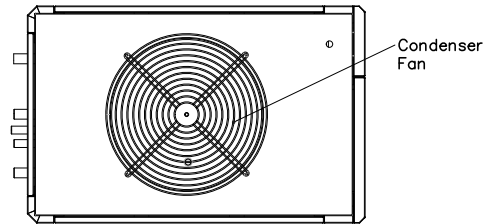
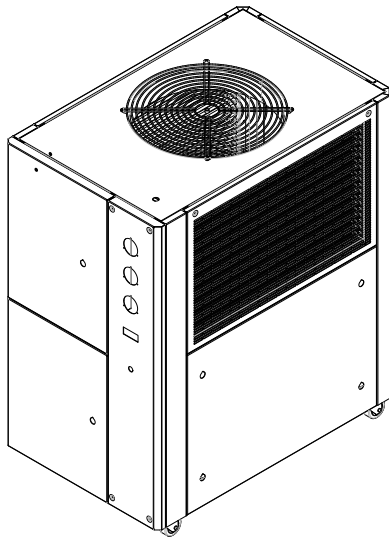
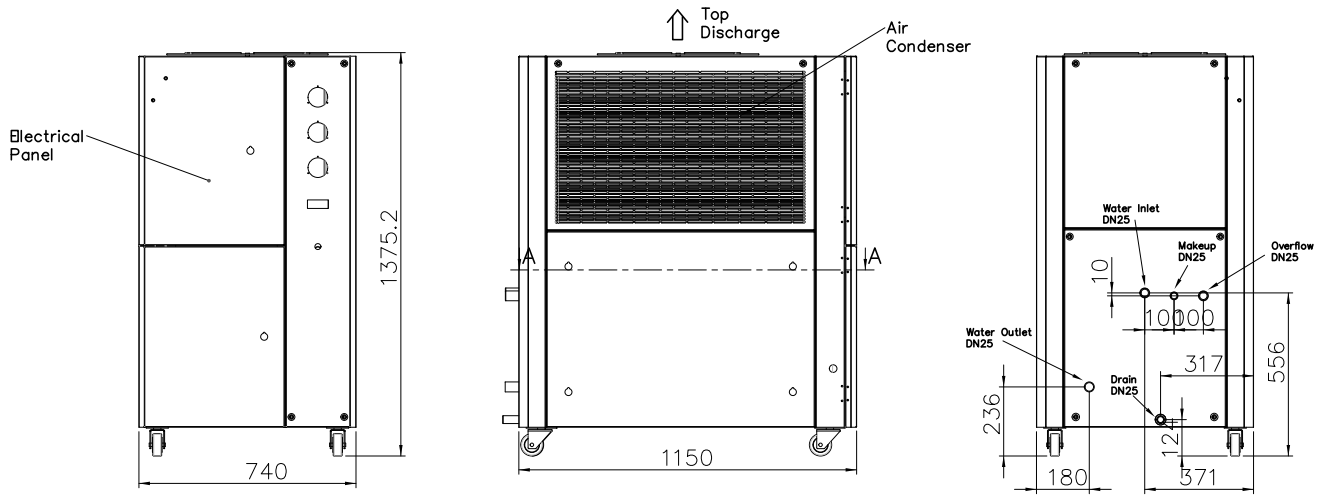

HYDRAULIC PERFORMANCE

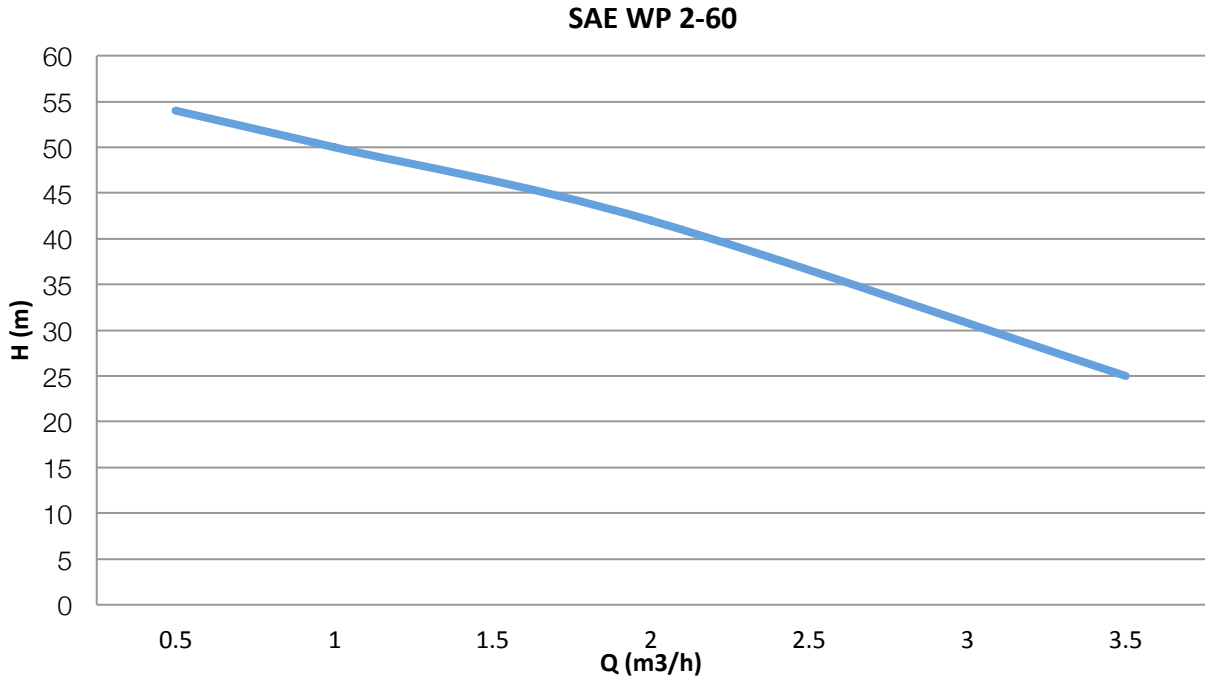

SAE WP 2-60
0.75 KW / 1.83 A

Q (m³/h)	0.5	1	1.5	2	2.5	3	3.5
H (m)	54	50	48	42	38	33	25

NOTES :

Shelton (S) Pte Ltd

Contact Us

Phone +65-6745 5553
Fax +65-6741 6038
Address 5A East Point Terrace, Kaki Bukit Road 3
Singapore 417826
Website www.shelton.com.sg

